



Funded by the  
Erasmus+ Programme  
of the European Union

# ELECTRICIAN

## Technical Description

### Set of tasks





Funded by the  
Erasmus+ Programme  
of the European Union

## INTRODUCTION

The name of the skills competition is electrician.

### **THE CONTENT, RELEVANCE AND SIGNIFICANCE OF THIS DOCUMENT**

Electrician „Set of tasks technical description“ is designed to understand the main technical organization procedures and tasks of Professional mastery competition „Balticskills“.

All competition organizers and participants must have analyzed the „Set of tasks technical description“.

In the event of any conflict within the different languages of the Technical Descriptions, the English version takes precedence.

### **PROFESSION DESCRIPTION**

An electrician works on commercial, residential, agricultural and industrial projects. The electrician has a continuing responsibility to work professionally in order to meet the requirements of the customer and thus maintain and grow the business. Electrical installation is closely associated with other parts of the construction industry, and with the many products that support it, normally for commercial purposes. The electrician works internally, including the homes of customers and on small and major projects. He or she will plan and design, select and install, commission, test, report, maintain, fault find and repair systems to a high standard. Work organisation and self-management, communication and interpersonal skills, problem solving, flexibility and a deep body of knowledge are the universal attributes of the outstanding electrician. Whether the electrician is working alone or in a team the individual takes on a high level of personal responsibility and autonomy. From working to provide a safe and reliable electrical installation and maintenance service, in accordance with relevant standards, through to diagnosing malfunctions, programming and commissioning home and building automation systems, concentration, precision, accuracy and attention to detail every step in the process matters and mistakes are largely irreversible, costly and potentially life threatening. With the international mobility of people the electrician faces rapidly expanding opportunities and challenges. For the talented electrician there are many





Funded by the  
Erasmus+ Programme  
of the European Union

commercial and international opportunities; however these carry with them the need to understand and work with diverse cultures and trends. The diversity of skills associated with electrical installations is therefore likely to expand.

## ASSESSMENT STANDARD SPECIFICATION

The Standards Specification specifies the knowledge, understanding and specific skills that underpin international best practice in technical and vocational performance. The Standards Specification is divided into distinct sections with headings and reference numbers added. The Marking Scheme and Test Project will assess only those skills that are set out in the Standards Specification. They will reflect the Standards Specification as comprehensively as possible within the constraints of the skill competition. The Marking Scheme and Test Project will follow the allocation of marks within the Standards Specification to the extent practically possible. A variation of five percent is allowed, provided that this does not distort the weightings assigned by the Standards Specification.

The assessment standard provides a skills assessment methodology.

Each section is assigned a percentage of the total marks to indicate its relative importance within the assessment standards specification. The sum of all the percentage marks is 100.

### Assessment standards specification

Competencies	Percentage
1. <b>Work organization and self-management</b>	<b>10</b>
<u>The individual needs to know and understand:</u> <ul style="list-style-type: none"><li>• health and safety legislation, obligations and documentation,</li><li>• the principles of working safely with electricity,</li><li>• the situations when personal protective equipment must be used,</li><li>• the purposes, uses, care, maintenance and storage of all tools and equipment together with their safety implications,</li><li>• the purposes, uses, care and storage of materials,</li></ul>	





Funded by the  
Erasmus+ Programme  
of the European Union

<ul style="list-style-type: none"><li>• the importance of keeping a tidy work area,</li><li>• sustainability measures applying to the use of 'green' materials and recycling,</li><li>• the ways in which working practices can minimise wastage and help to manage costs whilst maintaining quality,</li><li>• the principles of work flow and measurement,</li><li>• the significance of planning, accuracy, checking and attention to detail in all working practices,</li><li>• impact of new technology.</li></ul>	
<p><u>The individual shall be able to:</u></p> <ul style="list-style-type: none"><li>• follow health and safety standards, rules and regulations,</li><li>• diligently follow electrical safety procedures,</li><li>• identify and use the appropriate personal protective equipment including safety footwear, ear and eye protection,</li><li>• select, use, clean, maintain and store all tools and equipment safely,</li><li>• select, use and store all materials safely,</li><li>• identify and take care of expensive fixtures/fittings,</li><li>• plan the work area to maximise efficiency and maintain the discipline of regular tidying,</li><li>• measure accurately,</li><li>• manage time effectively,</li><li>• work efficiently and check progress and outcomes regularly,</li><li>• establish and consistently maintain high quality standards and working processes.</li></ul>	





Funded by the  
Erasmus+ Programme  
of the European Union

2.	<b>Communication and interpersonal skills</b>	<b>10</b>
	<p><u>The individual needs to know and understand:</u></p> <ul style="list-style-type: none"> <li>• the significance of establishing and maintaining customer confidence and trust • the importance of maintaining and keeping knowledge base upto-date,</li> <li>• the roles and requirements of related trades,</li> <li>• the value of building and maintaining productive working relationships,</li> <li>• techniques of effective teamwork,</li> <li>• the importance of swiftly resolving miss-understandings and conflicting demands.</li> </ul>	
	<p><u>The individual shall be able to:</u></p> <ul style="list-style-type: none"> <li>• interpret customer requirements and manage customer expectations positively,</li> <li>• provide advice and guidance on products/ solutions e.g. technological advancements,</li> <li>• visualise and translate customer wishes making recommendations which meet/improve their design and budgetary requirements,</li> <li>• question customers closely/deeply to fully understand requirements,</li> <li>• provide clear instructions,</li> <li>• introduce related trades to support customer requirements,</li> <li>• produce written reports for customers and the organisation,</li> <li>• produce a cost and time estimate for customers,</li> <li>• recognise and adapt to the changing needs of related trades,</li> </ul>	





Funded by the  
Erasmus+ Programme  
of the European Union

	<ul style="list-style-type: none"> <li>• work effectively as a member of a team.</li> </ul>	
3	<b>Problem solving, innovation and creativity</b>	10
	<p><u>The individual needs to know and understand:</u></p> <ul style="list-style-type: none"> <li>• the common types of problem which can occur within the work process,</li> <li>• diagnostic approaches to problem solving,</li> <li>• trends and developments in the industry including new technology, standards and working methods e.g. ‘smart house’ and energy saving measures.</li> </ul>	
	<p><u>The individual shall be able to:</u></p> <ul style="list-style-type: none"> <li>• check work regularly to minimise problems at a later stage,</li> <li>• identify problems originating from the work of a related trade e.g. heating pump, ventilation system etc.,</li> <li>• challenge incorrect information to prevent problems,</li> <li>• recognise and understand problems swiftly and follow a selfmanaged process for resolving,</li> <li>• recognise opportunities to contribute ideas to improve the solution and overall level of customer satisfaction,</li> <li>• demonstrate a willingness to try new methods and embrace change e.g. ready- made components.</li> </ul>	
4	<b>Planning and design</b>	10
	<p><u>The individual needs to know and understand:</u></p> <ul style="list-style-type: none"> <li>• different types of standards, drawings, installation descriptions and manuals,</li> </ul>	





Funded by the  
Erasmus+ Programme  
of the European Union

	<ul style="list-style-type: none"> <li>• range of materials and installation techniques to be used in different environments.</li> </ul>	
	<p><u>The individual shall be able to:</u></p> <ul style="list-style-type: none"> <li>• read, interpret and revise drawings and documentation including,</li> <li>• layout and circuit drawings,</li> <li>• follow written instructions,</li> <li>• plan installation work using drawings and documentation provided,</li> <li>• to answer some questions about Theoretical knowledge,</li> <li>• technology,</li> <li>• circuit technology,</li> <li>• operational analysis,</li> <li>• technical calculation.</li> </ul>	
<b>5</b>	<b>Installation</b>	40
	<p><u>The individual needs to know and understand:</u></p> <ul style="list-style-type: none"> <li>• ducting and wiring systems for commercial, domestic, residential agricultural and industrial use and when and where to use a specific ducting and/or wiring system,</li> <li>• the range of electrical switchboards used for commercial, domestic, residential, agricultural and industrial uses and when and where to use a specific switchboard system.</li> <li>• types of electric lighting and heating systems for commercial, domestic residential and industrial use,</li> </ul>	





Funded by the  
Erasmus+ Programme  
of the European Union

	<ul style="list-style-type: none"><li>• control devices and socket outlets used for commercial, domestic, residential, agricultural and industrial uses,</li><li>• structured cabling systems including: computer network cabling, fire/burglar alarm (conventional and addressable), evacuation control (audio and optical), control and monitoring, access control ('stand-alone' and 'network supervised'), closed circuit television (cameras, lenses and attachment component, recorders and monitors,</li><li>• building Automation Systems such as KNX.</li></ul>	
	<p><u>The individual shall be able to:</u></p> <ul style="list-style-type: none"><li>• select and install equipment and wire ways as per drawings and documentation,</li><li>• provided install ducting and cabling systems on different surfaces as per manufacturer's instructions and current industrial standards,</li><li>• select and install single and double insulated cables inside ducts,</li><li>• conduits and flexible conduits install and securely fix double insulated cables onto cable ladder, cable tray and different surfaces as per manufacturer's instructions and current industrial standards;</li><li>• install metal and plastic ducting (trunking): accurately measure and cut duct at specified lengths/ angles assemble without distortion to joints and to specified tolerances assemble different termination adaptors, including glands onto duct and attach ducts, of different types, securely onto a surface,</li></ul>	







Funded by the  
Erasmus+ Programme  
of the European Union

	<ul style="list-style-type: none"> <li>• install metal and plastic conduits/ flexible conduits and attach securely onto surface, maintaining even radius bends, without distortion,</li> <li>• to conduit correct termination adaptors used for entry of conduits into boxes, boards and ducts install and securely attach different types of cable ladder and cable tray to a surface install electrical switchboards onto a surface in a secure way and assemble switchboard apparatus in a switchboard as per layout drawings/instructions to include: main switches, RCDs, MCBs, fuses,</li> <li>• controlling equipment such as relays and timers and home and building automation devices terminate and install wiring inside a switchboard according to circuit drawings connect equipment as per instructions provided to include: structured cabling systems as per manufacturer's instructions and current industrial standards and regulations,</li> <li>• programming KNX Systems with devices like dimmactuator, blindactuator, roomcontrolling, movedetector.display, on/off actuator, different type of sensor.</li> </ul>	
6	<b>Testing, reporting and commissioning</b>	20
	<p><u>The individual needs to know and understand:</u></p> <ul style="list-style-type: none"> <li>• industrial regulations and standards applicable to different types ES2018_TD_Electrical_Installations_18 Version: 1 Date: 05.02.2018 10 of 23 of installations,</li> <li>• verification standards, methods and reports to be used to record verification results,</li> <li>• types of measuring instruments,</li> </ul>	





Funded by the  
Erasmus+ Programme  
of the European Union

	<ul style="list-style-type: none"><li>• tools and software used for parameterization, programming and commissioning,</li><li>• the correct operation of the electrical installation in accordance with the planned specification and customer requirements.</li></ul>	
	<b>Total</b>	<b>100%</b>

### 3. ASSESSMENT PRINCIPLES

All assessment will be governed by explicit benchmarks, referenced to best practice in industry and business. Competition tasks is the assessment vehicle for the skill competition, and also follows the Standards Specification.

#### SKILL ASSESSMENT SPECIFICATION

Imperfection description	Explanation	Limits for imperfections
Knowledge test	The participant takes a knowledge test, in which a certain number of points is obtained	80 points
Device "Starting the electric motor with star / triangle connection" assembly works, drive circuit assembly, troubleshooting and measurement of electrical parameters	The participant installs the assembly elements according to the assembly scheme.	100 points

#### SKILL ASSESSMENT PROCEDURES

Competition tasks:

1. Answer 60 test questions about electrical engineering.
2. Assemble the mounting elements according to the given assembly diagram.
3. Assemble and set the drive circuit according to the given motor drive diagram.
4. Take the necessary measurements for the correct operation of the drive circuit.





Funded by the  
Erasmus+ Programme  
of the European Union

## Knowledge test

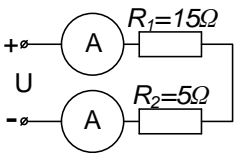
Question number	Points	Question	Answers
1.	1	<p>The total resistance of the four filament lamps is <math>1\Omega</math>. Determine the type of filament lamp connection if the resistance of one filament lamp is <math>4\Omega</math>.</p>	<ol style="list-style-type: none"><li>1. Series connection.</li><li>2. Parallel connection.</li><li>3. Mixed connection.</li><li>4. Star connection.</li></ol>
2.	1	<p>The mains voltage is 200V. Determine the difference between the ammeter readings!</p> 	<ol style="list-style-type: none"><li>1. 10A</li><li>2. 20A</li><li>3. 5A</li><li>4. 0A</li></ol>



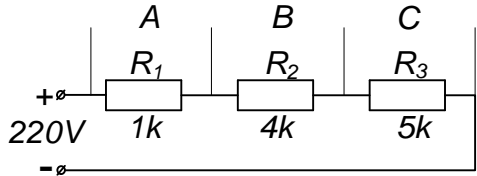
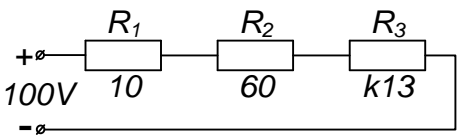

Funded by the  
Erasmus+ Programme  
of the European Union

3.	1	<b>What is an electric current?</b>	<ol style="list-style-type: none"><li>1. Electric current is the directional movement of electric charge carriers (electric particles);</li><li>2. Electric current is free neutrons;</li><li>3. Electric current is the difference between voltage and resistance.</li><li>4. The potential difference between two points in the electric field.</li></ol>
4.	1	<b>Calculate the voltage drop in stages A, B and C!</b> 	<ol style="list-style-type: none"><li>1. 22V, 88V, 110V</li><li>2. 110V, 88V, 22V</li><li>3. 88V, 110V, 55V</li><li>4. 88V, 127V, 66V</li></ol>
5.	1	<b>Calculate the current in the circuit!</b> 	<ol style="list-style-type: none"><li>1. 0,1A</li><li>2. 0,5A</li><li>3. 2A</li><li>4. 5A</li></ol>



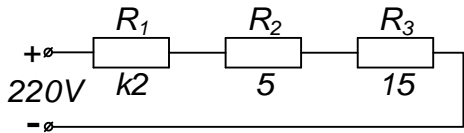
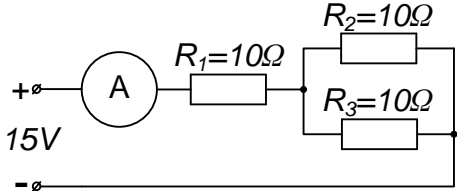

Funded by the  
Erasmus+ Programme  
of the European Union

6.	1	<p>Calculate the current in the circuit!</p> 	<ol style="list-style-type: none"><li>10A</li><li>1A</li><li>0,1A</li><li>0,01A</li></ol>
7.	1	<p>How much current will the ammeter show?</p> 	<ol style="list-style-type: none"><li>1A</li><li>2A</li><li>3A</li><li>0,5A</li></ol>
8.	1	<p>The electric soldering iron has a rated power of 60W and a rated current of 5A. What is the rated voltage of the soldering iron?</p>	<ol style="list-style-type: none"><li>60V</li><li>12V</li><li>220V</li><li>36V</li></ol>
9.	1	<p>What is the wattage of an incandescent lamp if its resistance to the operating state is 220Ω and the voltage is 110V?</p>	<ol style="list-style-type: none"><li>500W</li><li>110W</li><li>55W</li></ol>



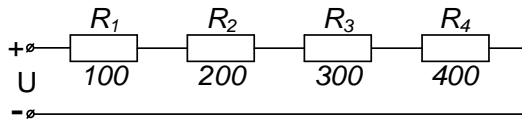

Funded by the  
Erasmus+ Programme  
of the European Union

			4. 0,5W
10.	1	What is the resistance of 100 resistors connected in parallel with a resistance of $120\Omega$ ?	1. 12000 $\Omega$ 2. 120 $\Omega$ 3. 12 $\Omega$ 4. 1,2 $\Omega$
11.	1	Which resistor will emit more heat (flowing current)? 	1. R1 2. R2 3. R3 4. R4
12.	1	What current flows in a wire with a resistance of $0.5M\Omega$ , if the voltage between the wire ends is $0.5kV$ ?	1. 10A 2. 1A 3. 1,5mA 4. 1mA
13.	1	How is energy converted in a DC generator?	1. Thermal energy is converted into electrical energy. 2. Electrical energy is converted into heat energy. 3. Mechanical energy is converted into direct current electrical energy.





Funded by the  
Erasmus+ Programme  
of the European Union

			4. Electrical energy is converted into mechanical energy.
14.	1	<p>The resistance of each resistor is <math>10\Omega</math>. What is the total resistance of the resistors in the given circuit?</p> <p><math>R_1=10\Omega</math> <math>R_2=10\Omega</math> <math>R_3=10\Omega</math> <math>R_4=10\Omega</math></p>	<ol style="list-style-type: none"><li>1. <math>2,5\Omega</math></li><li>2. <math>40\Omega</math></li><li>3. <math>80\Omega</math></li><li>4. <math>10\Omega</math></li></ol>
15.	1	<p>What is electrical voltage?</p>	<ol style="list-style-type: none"><li>1. Electrical voltage can be called the potential difference between two points;</li><li>2. Electrical voltage is the ratio of resistance to current;</li><li>3. Electrical voltage is the movement of electrical charges in conductors.</li><li>4. Electric current is free neutrons;</li></ol>





Funded by the  
Erasmus+ Programme  
of the European Union

16.	1	<p><b>Indicate in which of the schemes all elements of the scheme are correctly switched on!</b></p> <p>1. The first circuit. 2. The second circuit. 3. The third circuit. 4. The fourth circuit.</p> <hr/> <hr/>	
-----	---	---	--







Funded by the  
Erasmus+ Programme  
of the European Union

	1	<p>Indicate in which of the circuits two identical 110V incandescent lamps in the 220V network are correctly switched on!</p>	<p>1.                      2.                      3.                      4.</p>
	1	<p>The formula to find the effective value for sinusoidal alternating current:</p>	<ol style="list-style-type: none"> <li>1. <math>I = \sqrt{\frac{I_m^2}{2}}</math></li> <li>2. <math>I = \sqrt{3} * I_m</math></li> <li>3. <math>I = \frac{I_m}{\sqrt{3}}</math></li> <li>4. <math>I = \frac{I_m}{\sqrt{2}}</math></li> </ol>





Funded by the  
Erasmus+ Programme  
of the European Union

17.	1	<p>Voltmeter PV1 shows 36V. What voltage does the voltmeter PV2 show?</p> <p>The diagram shows a series circuit. On the left, there is a DC voltage source with a positive terminal (+) and a negative terminal (-). The circuit contains two resistors, <math>R_1 = 9\Omega</math> and <math>R_2 = 3\Omega</math>, connected in series. Two voltmeters, labeled PV1 and PV2, are connected in parallel across <math>R_1</math> and <math>R_2</math> respectively. An ammeter, labeled PA, is connected in series with the resistors. The circuit is completed by a wire connecting the negative terminal of the source to the right side of the ammeter.</p>	<ol style="list-style-type: none"><li>1. 6V</li><li>2. 12V</li><li>3. 24V</li><li>4. 36V</li></ol> <hr/>
18.	1	<p>The designation and unit of measurement of current, voltage and resistance is...</p>	<ol style="list-style-type: none"><li>1. R(Oms), U (Ampērs), I (Volts).</li><li>2. U (Oms ), I (Ampērs), R (Volts).</li><li>3. I (Ampērs), U (Volts), R (Oms).</li><li>4. U (Ampērs), R (Volts), I (Oms).</li></ol> <hr/>
19.	1	<p>Specify the DC power calculation formula!</p>	<ol style="list-style-type: none"><li>1. <math>A = IUt</math></li><li>2. <math>P = IU</math></li><li>3. <math>P = IU\cos\phi</math></li></ol> <p><math>A = Pt</math></p> <hr/>



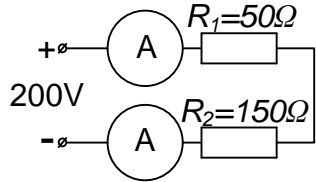

Funded by the  
Erasmus+ Programme  
of the European Union

20.	1	<p><b>Determine the voltage drop across resistor R1!</b></p> 	<ol style="list-style-type: none"><li>1. 5V</li><li>2. 50V</li><li>3. 100V</li><li>4. 150V</li></ol> <hr/>
21.	1	<p><b>What will be the total resistance if the eight conductors - each with a resistance of 10Ω - are closed in four equal parallel groups?</b></p>	<ol style="list-style-type: none"><li>1. 5Ω</li><li>2. 80Ω</li><li>3. 10Ω</li><li>4. 40Ω</li></ol> <hr/>
22.	1	<p><b>What will be the resistance of one bulb if four identical bulbs closed in parallel in a network with a voltage of 12V consume 2A of strong total current?</b></p>	<ol style="list-style-type: none"><li>1. 4,0Ω</li><li>2. 12,0Ω</li><li>3. 6,0Ω</li><li>4. 24Ω</li></ol> <hr/>
23.	1	<p><b>What will be the resistance of the electric hob spiral in the working position, if the electric hob spiral flows 5A strong current and the hob is connected to the 220V voltage network?</b></p>	<ol style="list-style-type: none"><li>1. 44Ω</li><li>2. 22Ω</li><li>3. 110Ω</li><li>4. 220Ω</li></ol> <hr/>





Funded by the  
Erasmus+ Programme  
of the European Union

24.	1	A strong current of 10A and a voltage of 40V are required to ensure a stable electric arc. How much extra resistance needs to be connected in series with the arc electrical equipment to be able to supply it with 120V voltage?	1. 4Ω 2. 12Ω 3. 8Ω 4. 3Ω
25.	1	Five resistors - 20Ω, 30Ω, 15Ω, 40Ω and 60Ω - are connected in parallel. What will be the total resistance?	1. 15Ω 2. 105Ω 3. 60Ω 4. 5,2Ω
26.	1	What is the power consumed by the electric hob if it consumes a large current from the mains 5A, but the helix resistance of the hob during operation is 24Ω?	1. 60W 2. 60kW 3. 0,6kW 4. 6W
27.	1	How much electricity does an electric oven consume in 30 minutes if a current of 10A is flowing in it and the mains voltage is 220V?	1. 1100Wh 2. 66000Wh 3. 2200Wh 4. 1200Wh





Funded by the  
Erasmus+ Programme  
of the European Union

28.	1	<b>On the base of the incandescent lamp is written: 200W, 220V. What is the resistance of the filament during operation?</b>	1. 1,1Ω 2. 0,9Ω 3. 242Ω 4. 240Ω
29.	1	<b>The power of the DC electric motor is 3kW. How much current flows in the winding of this motor if the mains voltage is 220 V?</b>	1. 1,36A 2. 13,64A 3. 15A 4. 0,36A
30.	1	<b>The battery is connected in series with five voltage sources with an EDS of 1.2V and an internal resistance of 0.2Ω. A resistance of 11Ω is connected to the voltage sources. How much current flows in the electrical circuit?</b>	1. 0,5 A 2. 0,55 A 3. 3,0 A 4. 0,6 A
31.	1	<b>The battery is connected from two batteries closed in parallel with EDS 2V of each battery and an internal resistance of 0.01Ω. The external resistance is 1.99Ω. How much current flows in the mains from the battery?</b>	1. 0,99A 2. 1,03A 3. 2,05A 4. 1,00A





Funded by the  
Erasmus+ Programme  
of the European Union

32.	1	The battery consists of four batteries, each EDS is 1.2V and the internal resistance is $0.2\Omega$ . A $4\Omega$ resistor is connected to the battery. How much current does the battery provide when the batteries are connected in series?	1. 0,296A 2. 1,00A 3. 4,185A 4. 1,5A
33.	1	Four batteries, each with EDS 1.2V and internal resistance $0.3\Omega$ , closed in series. The resistance of the external circuit is $8.4\Omega$ . How much current flows in the battery?	1. 0,55A 2. 0,67A 3. 0,14A 4. 0,50A
34.	1	Four batteries, each with EDS 1.2V and internal resistance $0.3\Omega$ , closed in series. The resistance of the external circuit is $8.4\Omega$ . What is its voltage?	1. 4,2V 2. 1,19V 3. 4,98V 4. 4,8V
35.	1	The battery consists of three parallel groups of batteries, each with five closed batteries in series, connected to an external mains with a resistance of $4.995\Omega$ . The EDS of the battery is 2V, the internal resistance is $0.003\Omega$ . How much current does the battery give?	1. 6A 2. 0,6A 3. 2A 4. 1,08A





Funded by the  
Erasmus+ Programme  
of the European Union

36.	1	The battery consists of three parallel groups of batteries, each with five closed batteries in series, connected to an external mains with a resistance of $4.995\Omega$ . The EDS of the battery is 2V, the internal resistance is $0.003\Omega$ . What power does the battery supply to the external circuit?	1. 60W 2. 19,7W 3. 11,7W 4. 20W
37.	1	How much current flows in the fifth lamp connected in series, if 0.3A flows in the first?	1. 0,3A 2. 1,5A 3. 0,06A 4. 0A
38.	1	How much power will be emitted on a series of resistors with resistances of $100\Omega$ , $200\Omega$ and $400\Omega$ if the connection voltage is 70V?	1. 70W 2. 49W 3. 75W 4. 7W
39.	1	What is the resistance when a current of 1 ampere is flowing and the battery voltage is 1 volt?	1. $0\Omega$ 2. $2\Omega$ 3. $1\Omega$ 4. $10\Omega$
40.	1	How many ohms is in 2 kilooms?	1. $2\Omega$ 2. $2000\Omega$ 3. $2000000\Omega$ 4. $0,0002\Omega$





Funded by the  
Erasmus+ Programme  
of the European Union

41.	1	<b>What is electrical resistance?</b>	<ol style="list-style-type: none"><li>1. The resistance of a conductor is called its resistance to the flow of electric current;</li><li>2. Conductor resistance is the ability to transfer loads from one end of a conductor to another;</li><li>3. The resistance of a conductor is the ratio of power to current.</li><li>4. Electrical voltage can be called the potential difference between two points;</li></ol>
42.	1	<b>How many milliamps are in 4 amps?</b>	<ol style="list-style-type: none"><li>1. 4mA</li><li>2. 4000000mA</li><li>3. 4000mA</li><li>4. 0,0004mA</li></ol>
43.	1	<b>Calculate the equivalent resistance if four identical 80Ω resistors are closed in parallel!</b>	<ol style="list-style-type: none"><li>1. 20Ω</li><li>2. 80Ω</li><li>3. 320Ω</li><li>4. 40Ω</li></ol>





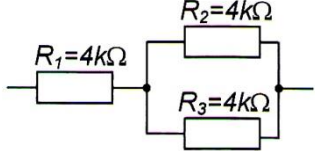

Funded by the  
Erasmus+ Programme  
of the European Union

44.	1	<b>What is the total resistance?</b> 	<ol style="list-style-type: none"><li>1. 1,33kΩ</li><li>2. 2kΩ</li><li>3. 6 kΩ</li><li>4. 12 kΩ</li></ol>
45.	1	<b>You can find the amount of electrical energy that is transformed to heat energy during time t by using:</b>	<ol style="list-style-type: none"><li>1. Joule-Lenz law</li><li>2. Lenz's law</li><li>3. Gauss's law</li><li>4. Coulumb's law</li></ol>
46.	1	<b>What is the total power of the same heating elements in a triangular circuit if the voltage between the phases is 400V and the current in the phase is 2.2A?</b>	<ol style="list-style-type: none"><li>1. 1524,2W</li><li>2. 2640W</li><li>3. 880W</li><li>4. 507,5W</li></ol>
47.	1	<b>Specify the DC power calculation formula!</b>	<ol style="list-style-type: none"><li>1. <math>A = IUt</math></li><li>2. <math>P = IU</math></li><li>3. <math>P = IU\cos\varphi</math></li><li>4. <math>A = Pt</math></li></ol>



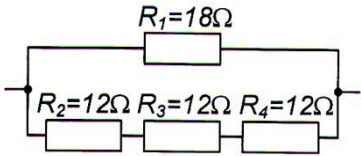
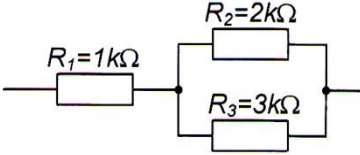

Funded by the  
Erasmus+ Programme  
of the European Union

48.	1	<b>How will the brightness and current of two bulbs closed in parallel change when a third bulb is connected in parallel?</b>	<ol style="list-style-type: none"><li>1. Brightness and current will increase.</li><li>2. Brightness and current will decrease.</li><li>3. The brightness will decrease and the current will increase.</li><li>4. The brightness will not change and the current will increase.</li></ol>
49.	1	<b>What is the total resistance?</b> 	<ol style="list-style-type: none"><li>1. 6,0Ω</li><li>2. 9,0Ω</li><li>3. 24Ω</li><li>4. 12Ω</li></ol>
50.	1	<b>What is the total resistance?</b> 	<ol style="list-style-type: none"><li>1. 1kΩ</li><li>2. 2,2kΩ</li><li>3. 4kΩ</li><li>4. 6kΩ</li></ol>



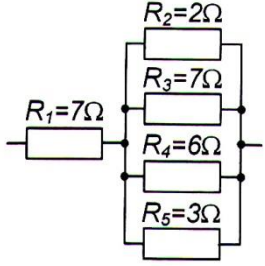
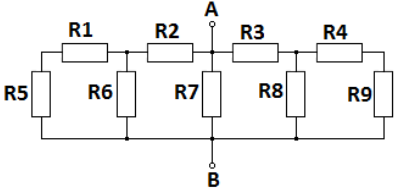

Funded by the  
Erasmus+ Programme  
of the European Union

51.	3	<p><b>What is the total resistance?</b></p> 	<ol style="list-style-type: none"><li>1. 25Ω</li><li>2. 5,5Ω</li><li>3. 7,88Ω</li><li>4. 10,0Ω</li></ol>
52.	3	<p><b>Calculate the electrical resistance of the circuit between points A and B,</b></p>  <p>Ja <math>R_1=R_2=R_3=R_4=R_5=R_9=45\Omega</math> un <math>R_6=R_7=R_8=90\Omega</math>!</p>	<ol style="list-style-type: none"><li>1. 30 Ω</li><li>2. 45 Ω</li><li>3. 90 Ω</li><li>4. 450 Ω</li></ol> <hr/>



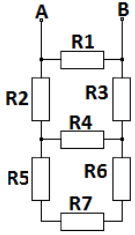
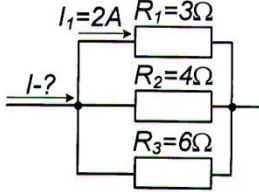

Funded by the  
Erasmus+ Programme  
of the European Union

53.	3	<p><b>Calculate the electrical resistance of the circuit between points A and B,</b></p> <p>ja <math>R_1=60\Omega</math>    <math>R_5=20\Omega</math> <math>R_2=15\Omega</math>    <math>R_6=30\Omega</math> <math>R_3=25\Omega</math>    <math>R_7=50\Omega</math> <math>R_4=100\Omega</math> !</p> 	<p>1. <math>36\ \Omega</math> 2. <math>45\ \Omega</math> 3. <math>100\ \Omega</math> 4. <math>300\ \Omega</math></p> <hr/>
54.	3	<p><b>What will be the total current?</b></p> 	<p>1. <math>4,5A</math> 2. <math>5,0A</math> 3. <math>6,0A</math> 4. <math>10,0A</math></p>





Funded by the  
Erasmus+ Programme  
of the European Union

55.	3	<p><b>How do you connect this motor to a 400 V mains?</b></p> <div data-bbox="689 379 1162 719" style="border: 1px solid black; padding: 5px;"><p>Motor &amp; Co GmbH</p><p>Typ 1601</p><p>3 ~ Mot. Nr. 12345-88</p><p><math>\Delta</math> <math>\Upsilon</math> 400/690 V 29/17 A</p><p>S1 15 kW cos <math>\varphi</math> 0,85</p><p>1430 U/min 50 Hz</p><p>Iso.-Kl. F IP 54 t</p><p>IEC34-1/VDE 0530</p></div>	<ol style="list-style-type: none"><li>1. Star;</li><li>2. Triangle;</li><li>3. Either a star or a triangle;</li><li>4. Mixed.</li></ol>
-----	---	--	---



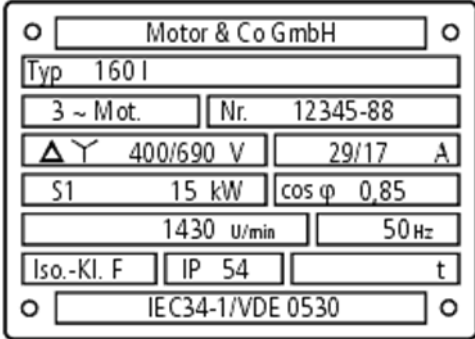

Funded by the  
Erasmus+ Programme  
of the European Union

56.	3	<p><b>How many poles does this motor have?</b></p>  <p>Motor &amp; Co GmbH Typ 1601 3 ~ Mot. Nr. 12345-88 <math>\Delta</math> Y 400/690 V 29/17 A S1 15 kW cos <math>\varphi</math> 0,85 1430 U/min 50 Hz Iso.-Kl. F IP 54 t IEC34-1/VDE 0530</p>	<ol style="list-style-type: none"><li>1. Two poles;</li><li>2. Three poles;</li><li>3. Four poles;</li><li>4. One pole.</li></ol>
-----	---	---	---



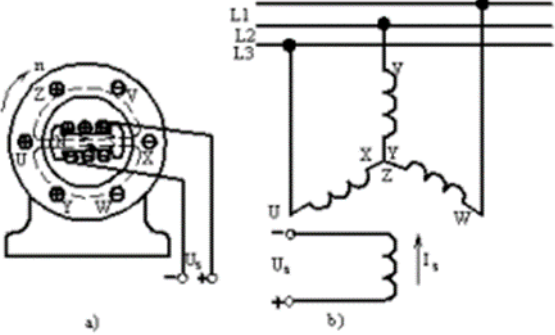

Funded by the  
Erasmus+ Programme  
of the European Union

57.	3	<p>What electric motor wiring diagram is shown?</p>  <p>a) b)</p>	<ol style="list-style-type: none"><li>1. Synchronous electric motor;</li><li>2. Asynchronous electric motor;</li><li>3. Single-phase electric motor with starting winding;</li><li>4. Stepper electric motor.</li></ol>
-----	---	---	---





Funded by the  
Erasmus+ Programme  
of the European Union

58.	3	<p><b>What does the inscription 100 A on an RCD mean?</b></p> 	<ol style="list-style-type: none"><li>1. Rated current;</li><li>2. Sensitivity;</li><li>3. Short circuit mode characteristic;</li><li>4. RCD model.</li></ol>
-----	---	--	---







Funded by the  
Erasmus+ Programme  
of the European Union

59.	3	<p><b>What happens if the cord breaks at the crosshair?</b></p> <p>The diagram shows a three-phase power supply system with phases L1, L2, and L3, and a neutral line N. Three consumers, U1, U2, and U3, are connected to the phases. A crosshair symbol indicates a break in the neutral line between U1 and U2.</p>	<ol style="list-style-type: none"><li>1. The power supply to U2 and U3 consumers will be cut off;</li><li>2. U2 and U3 users can receive increased voltage;</li><li>3. U2 and U3 users can get reduced voltage;</li><li>4. U1 user can receive increased voltage.</li></ol>
60.	3	<p><b>How is an asynchronous machine different from a synchronous machine?</b></p>	<ol style="list-style-type: none"><li>1. Stator magnetic field and rotor speed;</li><li>2. Stator and rotor dimensions;</li><li>3. Stator and rotor weights;</li><li>4. Stator and rotor material.</li></ol>





Funded by the  
Erasmus+ Programme  
of the European Union

## Schematics

### Description of the scheme

The circuit is started with a reduced voltage using the  $\lambda / \Delta$  switch. This limits the current surge when the engine is started, preventing the line guards from tripping. The engine can be started and stopped from two independent locations. The pneumatic time relay is used in the  $\lambda / \Delta$  switching scheme. By pressing one of the two START buttons, the voltage is applied to the contactor KM1, which implements the connection of the motor windings in a star circuit. Along with the magnetic starter KM1, the contactor KM2 also switches on, which supplies voltage to the windings U1, V1, W1 of the motor M. The time countdown is started by a pneumatic time relay located on the contactor KM2. After the set time, the contacts of the pneumatic time relay switch, which disconnects contactor KM1 and connects KM3. The windings of motor M are connected in a triangular circuit and the motor is operated at the rated supply voltage.



TARTU  
KUTSEHARIDUSKESKUS



JELGAVAS  
TEHNIKUMS



PROFESIONĀLĀS IZGLĪTĪBAS KOMPETENCES CENTRS

LIEPĀJAS VALSTS TEHNIKUMS



Funded by the  
Erasmus+ Programme  
of the European Union

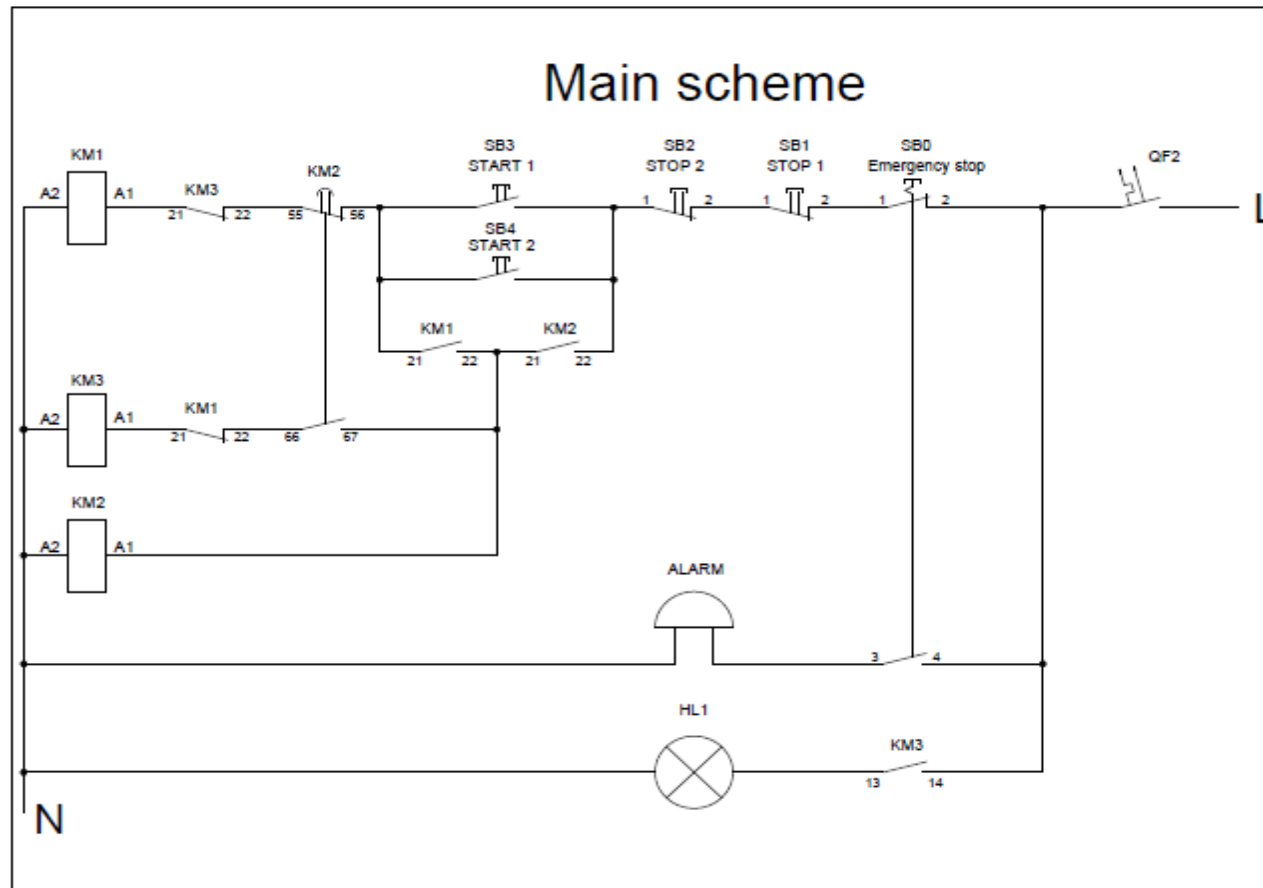



Funded by the  
Erasmus+ Programme  
of the European Union

## Drive diagram

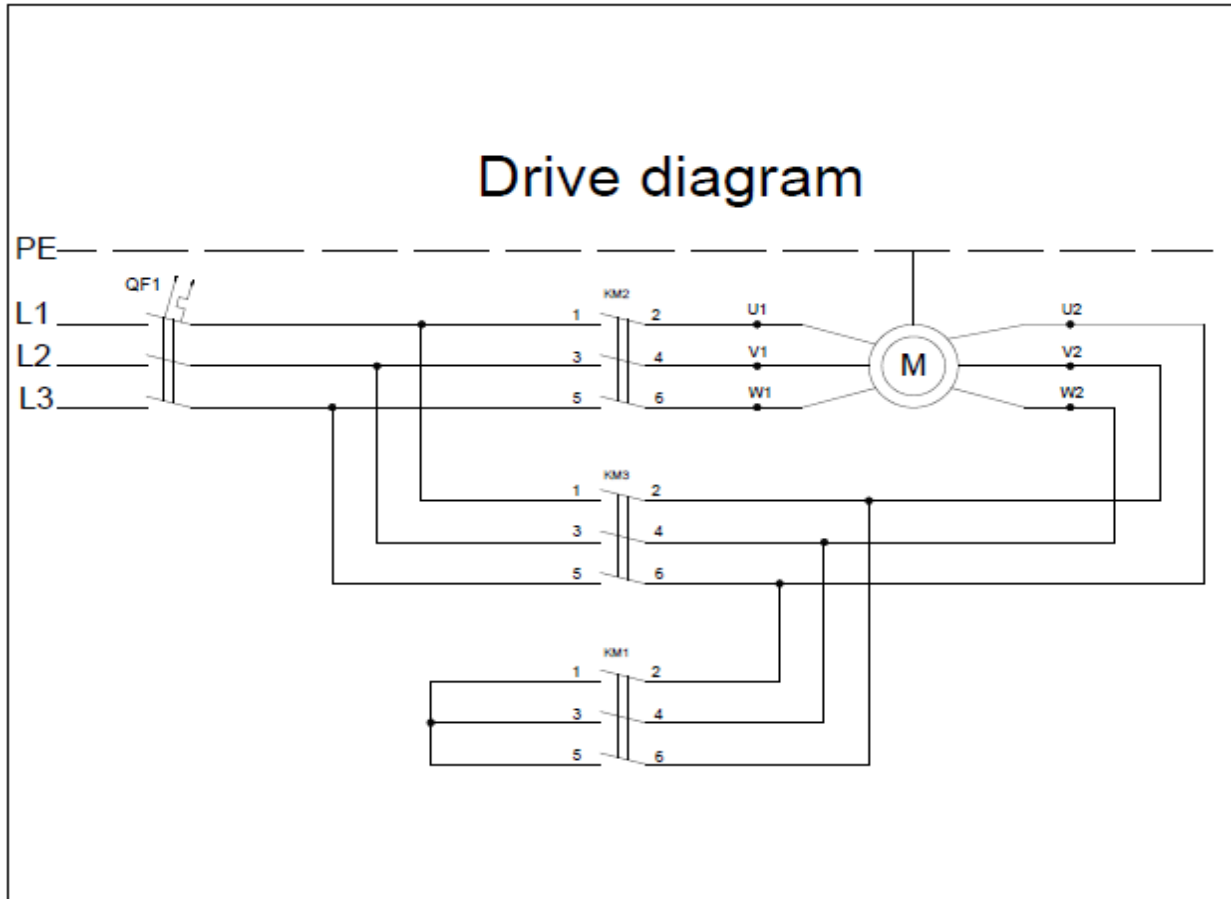

TARTU  
KUTSEHARIDUSKESKUS



JELGAVAS  
TEHNIKUMS





Funded by the  
Erasmus+ Programme  
of the European Union

## Electrical installation competition evaluation

### Performance evaluation form

Total number of points to be obtained – 100

Together **0,00**

A - Criterion - max points to be obtained 32 points

B- Criterion - max points to be obtained 40 points

C - Criterion - max points to be obtained 28 points

M- Measurement and V- Visual inspection

Criterion	Sub - criterion	Aspect	Type of assessment	Criterion evaluation in points	Evaluation of the aspect in points	Notes
<b>A. Installation of equipment and installation of wires / cables according to drawings</b>				32,00		
	<b>A.1. - Measurements</b>			<b>0,00</b>		



TARTU  
KUTSEHARIDUSKESKUS



JELGAVAS  
TEHNIKUMS

PROFESIONĀLĀS IZGLĪTĪBAS KOMPETENCES CENTRS



LIEPĀJAS VALSTS TEHNIKUMS



Funded by the  
Erasmus+ Programme  
of the European Union

		A.1.1. Measurement according to the drawing Drawing 1, p.1.	M		2,00	795mm, $\pm 5$ mm
		A.1.2. Measurement according to the drawing Drawing 1, p.2.	M		2,00	320mm, $\pm 3$ mm
		A.1.3. Measurement according to the drawing Drawing 1, p.3.	M		2,00	900mm, $\pm 5$ mm
		A.1.4. Measurement according to the drawing Drawing 1, p.4.	M		2,00	370mm, $\pm 3$ mm
		A.1.5. Measurement according to the drawing Drawing1, p.5.	M		2,00	385mm, $\pm 3$ mm



TARTU  
KUTSEHARIDUSKESKUS



JELGAVAS  
TEHNIKUMS

PROFESIONĀLĀS IZGLĪTĪBAS KOMPETENCES CENTRS



LIEPĀJAS VALSTS TEHNIKUMS



Funded by the  
Erasmus+ Programme  
of the European Union

		A.1.6. Measurement according to the drawing Drawing 1, p.6.	M		2,00	620mm, ±5mm
		A.1.7. Measurement according to the drawing Drawing 1, p.7.	M		2,00	230mm, ±3mm
	<b>A.2. -Levels</b>					
		A.2.1. Level, drawing, p.L1	V		2,00	Level bubble / Inside points x1 / On line points x0.5 / Outside = 0
		A.2.2. Level, drawing, p.L2	V		2,00	Level bubble / Inside points x1 / On line points x0.5 / Outside = 0
		A.2.3. Level, drawing p.L3	V		2,00	Level bubble / Inside points x1 / On line points x0.5 / Outside = 0
	<b>A.3. Quality</b>					
		A.3.1. Creating joints p.S1.	M		3,00	>4mm=0, 2-4mm=1, 1-2mm=2, <1mm=3





Funded by the  
Erasmus+ Programme  
of the European Union

		A.3.2. Creating joints p.S2.	M		3,00	>4mm=0, 2-4mm=1, 1-2mm=2, <1mm=4
		A.3.3. Creating joints p.S3.	M		3,00	>4mm=0, 2-4mm=1, 1-2mm=2, <1mm=5
		A.3.4. Creating joints p.S4.	M		3,00	>4mm=0, 2-4mm=1, 1-2mm=2, <1mm=6
<b>B. Equipment functions</b>					40,00	
	<b>B.1. Functionality</b>				0,00	
Power scheme	Pressing SB3 or SB4 switches on KM1 and KM2	B.1.1. Function 1	V		2,00	
	Start -time-"star-triangle"	B.1.2. Function 2	V		3,00	
	HL1 turns on when the triangle	B.1.3. Function 3	V		2,00	
	SB0, Emergency stop	B.1.4. Function 4	V		3,00	
	SB1, Stop	B.1.5. Function 5	V		3,00	
	SB2, Stop	B.1.6. Function 6	V		3,00	
	SB3 Start 1	B.1.7. Function 7	V		3,00	
	SB4 Start 2	B.1.8. Function 8	V		3,00	
	Call rings by pressing SB0	B.1.9. Function 9	V		3,00	







Funded by the  
Erasmus+ Programme  
of the European Union

	Quality of contactor connections	B.1.10. Function 10	V		3,00	Copper 90gr. Visible -1p per strand
	Connection quality HL1	B.1.11. Function 11	V		3,00	Copper 90gr. Visible -1p per strand
	Connection quality SB0	B.1.12. Function 12	V		3,00	Copper 90gr. Visible -1p per strand
	Connection quality SB1, SB3	B.1.13. Function 13	V		3,00	Copper 90gr. Visible -1p per strand
	Connection quality SB2, SB4	B.1.14. Function 14	V		3,00	Copper 90gr. Visible -1p per strand
<b>C.</b>	<b>Workplace safety and order</b>				<b>28,00</b>	
	<b>F.1.</b>	<b>Work safety Day 1</b>			<b>0,00</b>	
		C.1.1. Use of earplugs when working with power tools	V		0,40	For a remark 1x, -0,2p.
		C.1.2. Use of safety goggles when sawing and drilling	V		0,40	For a remark 1x, -0,2p.





Funded by the  
Erasmus+ Programme  
of the European Union

		C.1.3. Use of gloves when sawing and drilling metal and wood	V		0,40	For a remark 1x, -0,2p.
		C.1.4. Use of work shoes and clothes	V		0,40	For a remark 1x, -0,2p.
		C.1.5. Workplace arrangements at the end of the day	V		5,40	
	<b>F.2 Work safety Day 2</b>					
		C.2.1. Use of earplugs when working with power tools	V		0,40	For a remark 1x, -0,2p.
		C.2.2. Use of safety goggles when sawing and drilling	V		0,40	For a remark 1x, -0,2p.



TARTU  
KUTSEHARIDUSKESKUS



JELGAVAS  
TEHNIKUMS

PROFESIONĀLĀS IZGLĪTĪBAS KOMPETENCES CENTRS



LIEPĀJAS VALSTS TEHNIKUMS



Funded by the  
Erasmus+ Programme  
of the European Union

		C.2.3. Use of gloves when sawing and drilling metal and wood	V		0,40	For a remark 1x, -0,2p.
		C.2.4. Use of work shoes and clothes	V		040	For a remark 1x, -0,2p.
		C.2.5. Workplace arrangements at the end of the day	V		5,40	
	<b>C.3.The overall view</b>					
		C.3.1. Overall visual assessment	V		14,00	0-there are guides, fingerprints, dirt. 1-screw holes, fingerprints, scratches. 2-some lines. 3-only "0" lines

